

# Flex Switch™ Specs

## RS1 Wireless Switching Guide

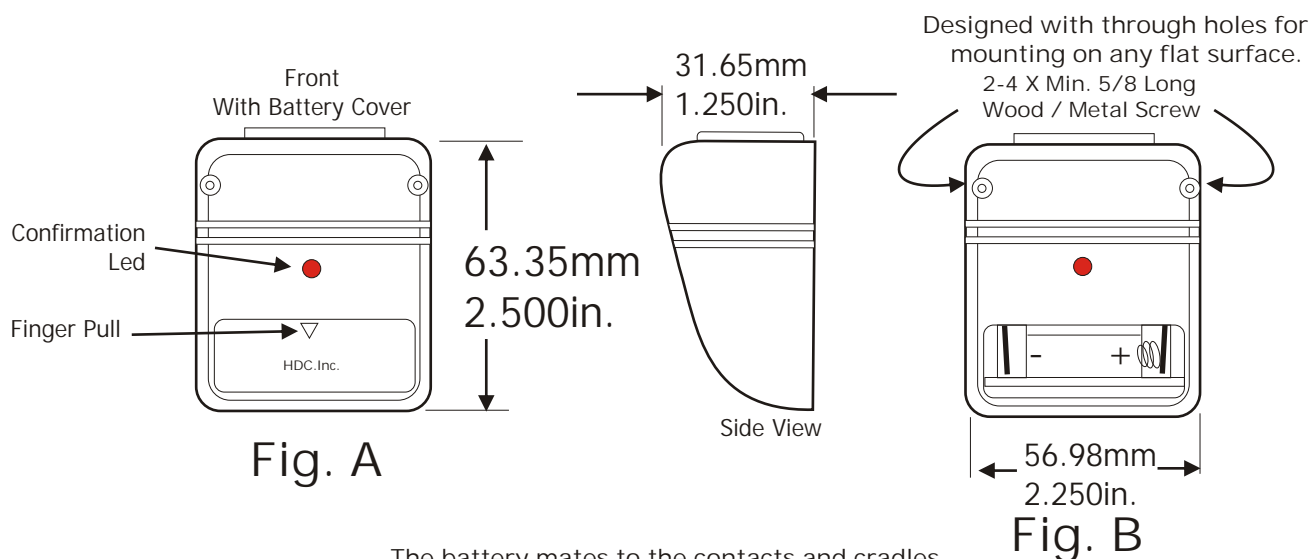

The battery mates to the contacts and cradles inside the bezel. Battery held in place only by cover and contacts.

To replace the Flex Switch battery, the battery cover must be removed. Using only a fingernail in the depression just above the HDC Inc. shown in Fig. A, remove cover. Once removed, battery is visible and accessible. Replacement batteries are 12v part # GP23A, CN23A, EL12 and VR22 or similar class battery.

Replacement battery must be installed as shown in Fig. B. Its orientation is specific to - + polarities clearly marked.

Replace cover and test.



Flex Switch™ (RS 2)

# Flex Switch™ Specs

## RS2 Wireless Switching Guide

Front and Cover

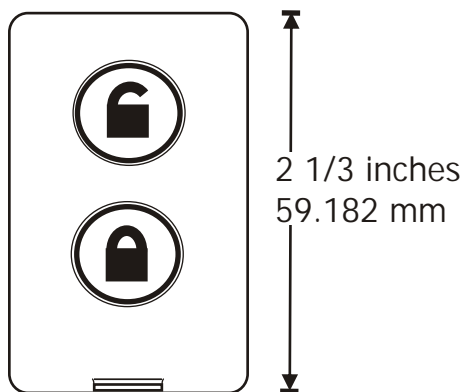

Depress to open

Fig. A

Side



.5 inches  
12.7 mm

Front with no cover

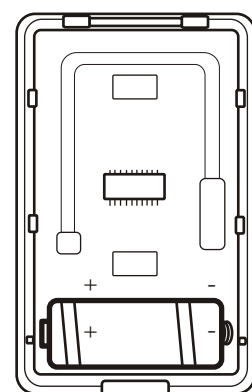

1.5 inches  
38.1 mm

Fig. B

The battery mates to the contacts and cradles inside the bezel. Battery held in place only by cover and contacts.

To replace the Flex Switch, the battery cover must be removed. Using only a fingernail or pen tip, depress the tab on the bottom of the flex switch. Cover will hinge at the top revealing the inside components. Replacement batteries are 12v part # GP23A, CN23A, EI12 and Vr22 or similar class battery.

Replacement battery must be installed as shown in Fig B. Its orientation is specific to +- polarities clearly marked.

Replace cover and test.

- 1.) Use only plastic approved paints
- 2.) Clean surface to be painted as per paint MFG recommends
- 3.) Allow to dry sufficiently before replacement and use.



Flex Switch™ (RS 2)